

## Thyristor module PSKT 184M

$I_{T(RMS)} = 2 \times 286 \text{ A}$   
 $I_{T(AV)} = 2 \times 182 \text{ A}$   
 $V_{RRM} = 800-1800 \text{ V}$

### Preliminary Data Sheet

$V_{RSM}$ V	$V_{RRM}$ V	Type
900	800	PSKT 184M/08
1100	1000	PSKT 184M/10
1300	1200	PSKT 184M/12
1500	1400	PSKT 184M/14
1700	1600	PSKT 184M/16
1900	1800	PSKT 184M/18

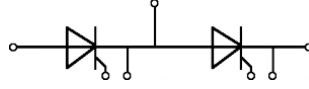

Symbol	Test Conditions	Maximum Ratings
$I_{T(RMS)}$	$T_{VJ} = 125^\circ\text{C}$	half sine 286 A
$I_{T(AV)}$	$T_C = 85^\circ\text{C}$	182 A
$I_{TSM}$	$T_{VJ} = 125^\circ\text{C}$ $t = 10 \text{ ms}$	half sine 7000 A
$\int i^2 dt$	$T_{VJ} = 125^\circ\text{C}$ $t = 10 \text{ ms}$	half sine 245 $\text{A}^2 \text{ s} \cdot 10^3$
$(di/dt)_{cr}$	$T_{VJ} = 125^\circ\text{C}$ $t_r \leq 0,5 \mu\text{s}$	gate source 1,5A 200 $\text{A}/\mu\text{s}$
$(dv/dt)_{cr}$	$T_{VJ} = 125^\circ\text{C}$ $V_{DM} = 2/3 V_{DRM}$	1000 $\text{V}/\mu\text{s}$
$T_{VJ}$		-40 ... + 125 $^\circ\text{C}$
$T_{VJM}$		125 $^\circ\text{C}$
$T_{stg}$		-40 ... + 125 $^\circ\text{C}$
$V_{ISOL}$	50 HZ, RMS $t = 1 \text{ min}$ $I_{ISOL} \leq 1 \text{ mA}$	min. 3000 V ~
$M_d$	Terminal connection torque (M6)	6,0 Nm
	Mounting torque (M6)	6,0 Nm
Weight	typ.	285 g

### Features

- Isolated mounting base 3000V~
- Pressure contact technology with increased power cycling capability

### Applications

- AC/DC Motor drives
- Various rectifiers
- DC supply for PWM inverter

### Advantages

- Easy to mount with two screws
- Space and weight savings
- Improved temperature and power cycling capability

### Package, style and outline

Dimensions in mm (1mm = 0.0394")

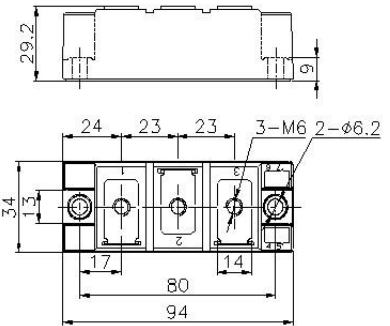

Symbol	Test Conditions	Characteristic Value
$I_{RRM}; I_{DRM}$	$V_R = V_{RRM}$ $T_{VJ} = 125^\circ\text{C}$ $V_D = V_{DRM}$	$\leq 25 \text{ mA}$
$V_{TM}$	$I_{TM} = 550 \text{ A}$ $T_{VJ} = 25^\circ\text{C}$	$\leq 1,62 \text{ V}$
$V_{TO}$	For power-loss calculations only	0,80 V
$r_T$	$T_{VJ} = 125^\circ\text{C}$	1,26 $\text{m}\Omega$
$I_{GT}$		30-150 mA
$V_{GT}$	$V_A = 12 \text{ V}$ $T_{VJ} = 25^\circ\text{C}$ $I_A = 1 \text{ A}$	1,0-2,5 V
$I_H$		20-150 mA
$V_{GD}$	$V_{DM} = 2/3 V_{DRM}$ $T_{VJ} = 125^\circ\text{C}$	0,2 V
$R_{th(j-c)}$	Per chip; Single side cooled	0,16 $^\circ\text{C}/\text{W}$